

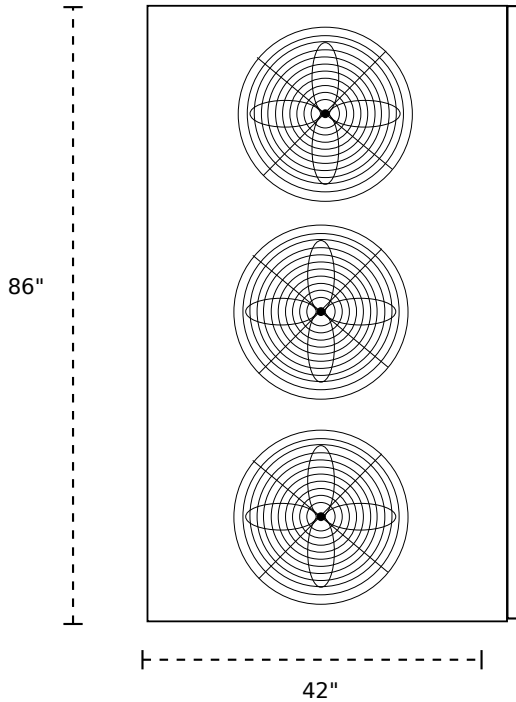

TOP

## 20 TON SPLIT DEHU

### MODEL DU20T29CK696-3-SPLIT



#### SPECIFICATIONS:

- 20 ton dehumidifier
  - Performance: 27.8 gallons per hour @ 80F and 60% relative humidity
  - 29 gallons per hour, 696 gallons per day
  - 12.63 pints per KW
  - Electrical: 208/230V, 60hz three phase
  - Minimum Circuit Ampacity: 5, Maximum Fuse Size 15 Amps
  - R410a Refrigerant
  - Two remote condensers, specs on next page
  - Scroll compressor, specs on next page
  - CFM: 6,000
  - Dimensions:
    - Inside unit 86" wide, 42" long, 48" tall
    - Outside remote units (2) each 35-1/2" wide, 35-1/2" long, 38-1/4" tall
  - Decibels: 84
  - Weight (LBS): 1405
- #### ADDITIONAL FEATURES:
- Cold air discharge only inside.

SIDE

FRONT

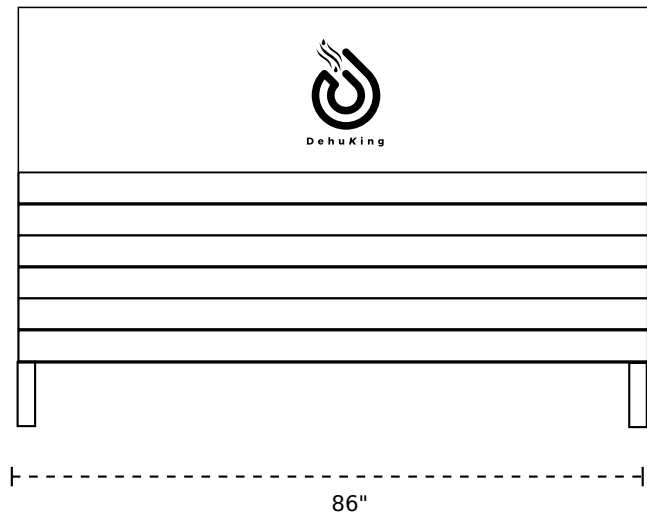
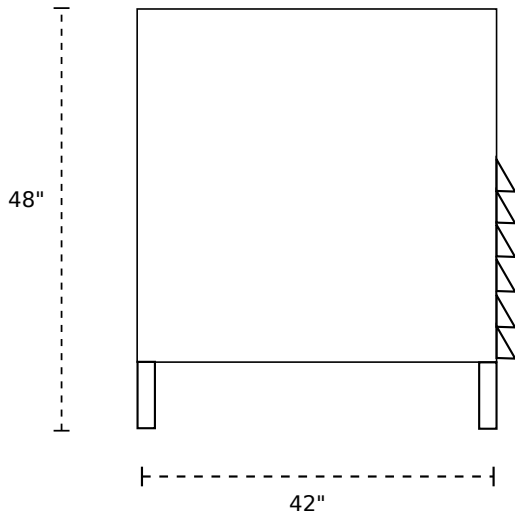



TOP

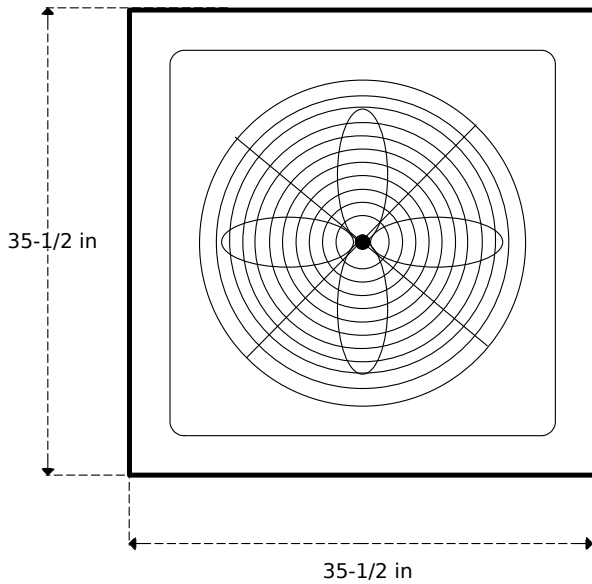

## MODEL DU20T29CK696-3-SPLIT

- Two remote condensers each:
- Electrical: 208/230v
- Minimum Circuit Ampacity: 46.4 Amps, Maximum Fuse Size 70 Amps
- Each with 120,000 BTU/HR Copeland scroll compressor
- Dimensions (each): 35-1/2" wide, 35-1/2" long, 38-1/4" tall
- Approximate shipping weight (LBS): 301 each
- Decibels: 72

FRONT

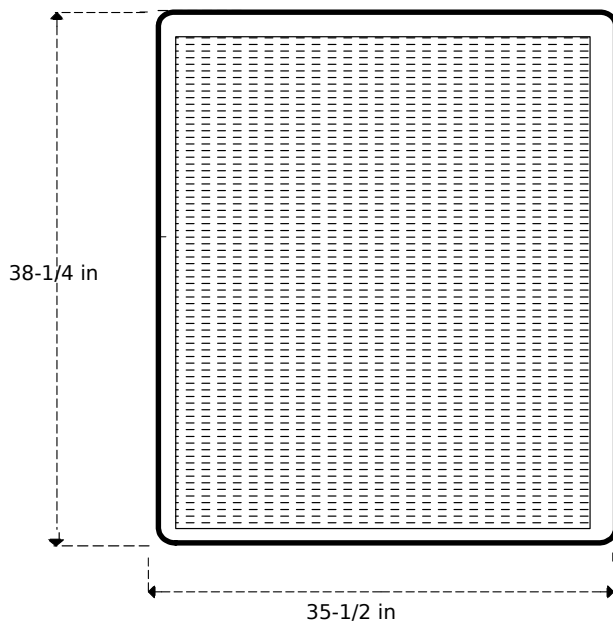

REAR

