

CHILLKING

Chiller Systems

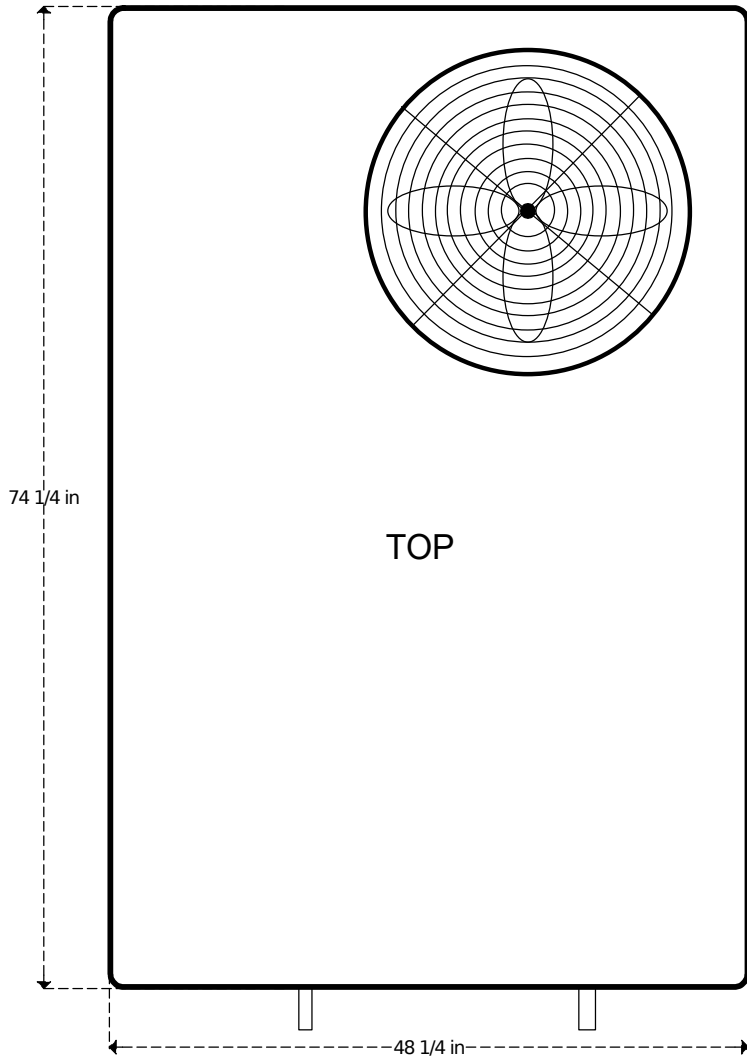

MODEL GC48CK4-LT

SPECIFICATIONS:

- Low temperature chiller
- 52,800 BTU/HR at 55F LWT and 90F ambient
- 23,000 BTU/HR at 28F LWT and 90F ambient
- Electrical: 460V, 60hz three phase
- Minimum Circuit Ampacity: 11, Maximum Fuse Size 16 Amps
- One 44 gallon stainless steel tank with Chillking evaporator coil inside
- 1 HP water pump: 47 GPM max, 49 PSI max
- R410a Refrigerant
- One 48,000 BTU/HR Copeland scroll compressor
- Approximate shipping weight 800 LBS
- Dimensions: 48-1/4" wide, 74-1/4" long, 38-3/4" tall
- Decibels: 78

FRONT

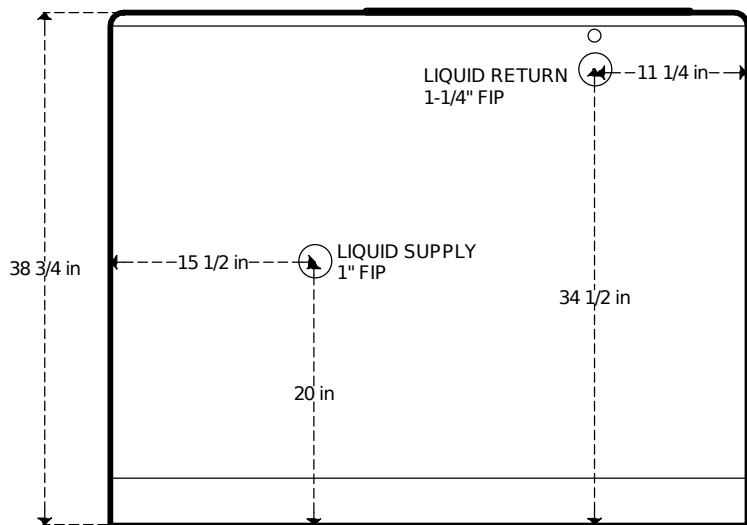

REAR

