

# CHILLKING

## Chiller Systems

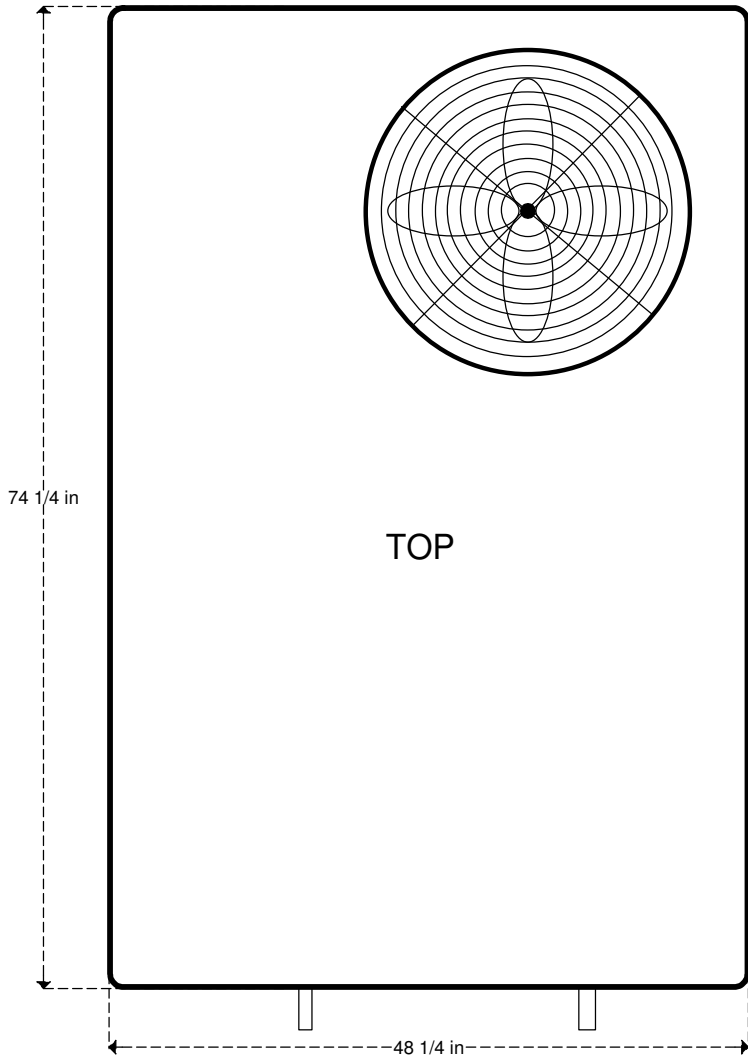

### MODEL GC36CK1

#### SPECIFICATIONS:

- 36,000 BTU/HR at 95F degree ambient and 55F degree water out
- Electrical: 208/230V, 60hz single phase
- Minimum Circuit Ampacity: 30, Maximum Fuse Size 46 Amps
- One 30 gallon stainless steel tank with Chillking evaporator coil
- 1 HP water pump: 47 GPM max, 49 PSI max
- R410a Refrigerant
- One 36,000 BTU/HR Copeland scroll compressor
- Approximate shipping weight 700 LBS
- Dimensions: 48-1/4" wide, 74-1/4" long, 38-3/4" tall
- Decibels: 78

#### FRONT

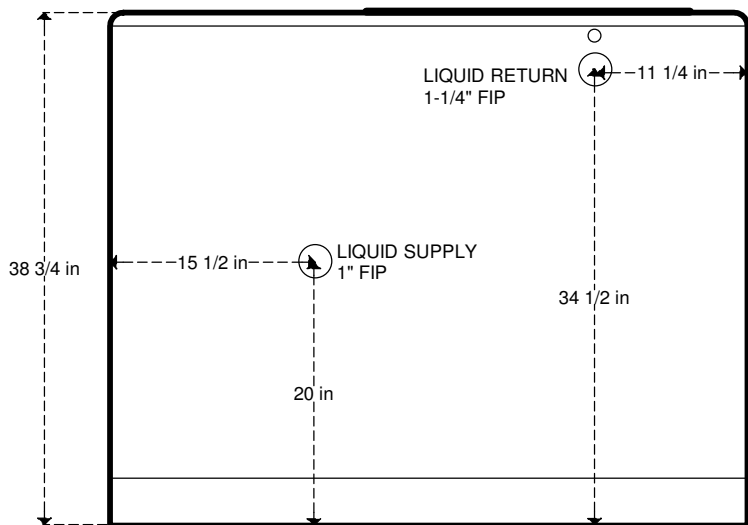

#### REAR

