

DehuKing

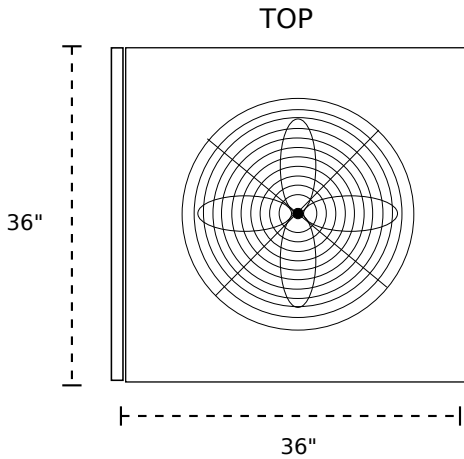

MODEL DU05T07UV172-1376-3

SPECIFICATIONS:

- 5 ton dehumidifier
- 7 gallons per hour, 172 gallons per day, 1376 pints per day
- 14 pints per KW
- Ultraviolet purification
- Electrical: 208/230V, 60hz three phase
- Minimum Circuit Ampacity: 22, Maximum Fuse Size 37 Amps
- R410a Refrigerant
- One 60,000 BTU/HR Copeland Scroll Compressors
- Dimensions: 89" wide, 36" long, 72" tall
- Decibels: 84

